

# Product data sheet

## Characteristics

# RM17TE00

Zelio, 3 phase supply control relay, range 208 to 480 VAC, sequence, phase failure, phase imbalance, voltage

Product availability : Stock - Normally stocked in distribution facility



Price\*\* : 217.00 USD



### Main

Range of product	Zelio Control
Product or component type	Modular measurement and control relays
Relay type	Multifunction control relay
Product specific application	For 3-phase supply
Relay name	RM17TE
Relay monitored parameters	Undervoltage and overvoltage in window mode Asymmetry Phase sequence Phase failure detection
Time delay	Adjustable 0.1...10 s, +/- 10 % of the full scale value
Switching capacity in VA	1250 VA
Measurement range	208...480 V voltage AC

### Complementary

Reset time	1500 ms time delay
Maximum switching voltage	250 V AC 250 V DC
Minimum switching current	10 mA 5 V DC
Maximum switching current	5 A AC 5 A DC
Supply voltage limits	183...528 V AC
Control circuit voltage limits	- 12 % + 10 % Un
Power consumption in VA	0...22 VA 400 V AC 50 Hz
Control circuit frequency	50...60 Hz +/- 10 %
Output contacts	1 C/O
Nominal output current	5 A

Measurement voltage limits	183...528 V AC
Hysteresis	2 %
Delay at power up	650 ms
Maximum measuring cycle	150 ms measurement cycle as true rms value
Threshold adjustment voltage	-2...-17 % in the range 220 V AC +2...+17 % in the range 480 V AC -2...-12 % in the range 208 V AC 2...20 % of Un selected
Voltage range	208...480 V phase to phase
Adjustment of asymmetry threshold	5...15 % of Un selected
Repeat accuracy	0.5 % input and measurement circuit 3 % time delay
Measurement error	< 0.05 %/°C with temperature variation < 1 % over the whole range with voltage variation
Phase failure sensitivity	0.7 Un
Response time	< 200 ms in the event of a fault)
Marking	CE
Overvoltage category	III IEC 60664-1
Insulation resistance	> 500 MOhm 500 V DC IEC 60255-5 > 500 MOhm 500 V DC IEC 60664-1
[Ui] rated insulation voltage	400 V IEC 60664-1
Supply frequency	50/60 Hz +/- 10 %
Operating position	Any position without
Connections - terminals	Screw terminals, 1 x 0.5...1 x 4 mm <sup>2</sup> AWG 20...AWG 11) solid without cable end Screw terminals, 2 x 0.5...2 x 2.5 mm <sup>2</sup> AWG 20...AWG 14) solid without cable end Screw terminals, 1 x 0.2...1 x 2.5 mm <sup>2</sup> AWG 24...AWG 12) flexible with cable end Screw terminals, 2 x 0.2...2 x 1.5 mm <sup>2</sup> AWG 24...AWG 16) flexible with cable end
Tightening torque	5.31...8.85 lbf.in (0.6...1 N.m) IEC 60947-1
Housing material	Self-extinguishing plastic
Local signalling	Power ON LED green) Relay ON LED yellow)
Mounting support	35 mm symmetrical DIN rail EN/IEC 60715
Electrical durability	100000 cycles
Mechanical durability	30000000 cycles
Operating rate	<= 360 operations/hour full load
Utilisation category	AC-12 IEC 60947-5-1 AC-13 IEC 60947-5-1 AC-14 IEC 60947-5-1 AC-15 IEC 60947-5-1 DC-12 IEC 60947-5-1 DC-13 IEC 60947-5-1
Safety reliability data	MTTFd = 502.2 years B10d = 470000
Width	0.69 in (17.5 mm)
Net weight	0.29 lb(US) (0.13 kg)

## Environment

Electromagnetic compatibility	Emission standard for industrial environments EN/IEC 61000-6-4 Emission standard for residential, commercial and light-industrial environments EN/IEC 61000-6-3 Immunity for industrial environments EN/IEC 61000-6-2
Standards	EN/IEC 60255-1
Product certifications	GOST C-Tick CSA UL GL
Directives	89/336/EEC - electromagnetic compatibility 73/23/EEC - low voltage directive
Ambient air temperature for storage	-40...158 °F (-40...70 °C)

Ambient air temperature for operation	-4...122 °F (-20...50 °C)
Relative humidity	95 % 131 °F (55 °C) IEC 60068-2-30
Vibration resistance	0.35 mm 5...57.6 Hz)IEC 60068-2-6 1 gn 57.6...150 Hz)IEC 60255-21-1
Shock resistance	15 gn 11 ms IEC 60255-21-1
IP degree of protection	IP20 IEC 60529 terminals) IP30 IEC 60529 casing)
Pollution degree	3 IEC 60664-1
Dielectric test voltage	2 kV AC 50 Hz, 1 min IEC 60255-5 2 kV AC 50 Hz, 1 min IEC 60664-1
Non-dissipating shock wave	4 kV IEC 60255-5 4 kV IEC 60664-1 4 kV IEC 61000-4-5

### Ordering and shipping details

Category	22380 - RELAYS-MEASUREMENT (RM17-RM35)
Discount Schedule	CP2
GTIN	00785901662181
Package weight(Lbs)	0.09 kg (0.2 lb(US))
Returnability	Yes
Country of origin	ID

### Offer Sustainability

Sustainable offer status	Green Premium product
REACH Regulation	<a href="#">REACH Declaration</a>
EU RoHS Directive	Pro-active compliance (Product out of EU RoHS legal scope) <a href="#">EU RoHS Declaration</a>
Mercury free	Yes
RoHS exemption information	<a href="#">Yes</a>
China RoHS Regulation	<a href="#">China RoHS declaration</a>
Environmental Disclosure	<a href="#">Product Environmental Profile</a>
Circularity Profile	<a href="#">End of Life Information</a>
WEEE	The product must be disposed on European Union markets following specific waste collection and never end up in rubbish bins.

### Contractual warranty

Warranty	18 months
----------	-----------

Multifunction 3-Phase Supply Control Relays

Dimensions and Mounting

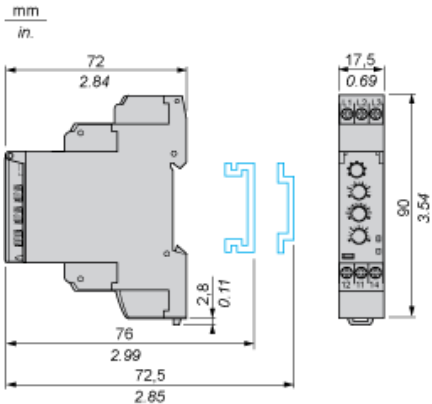

---

Multifunction 3-Phase Supply Control Relays

---

Wiring Diagram

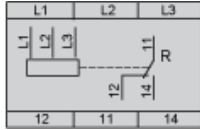

Function Diagrams

Phase Sequence Control, Phase Failure Detection (U measured < 0.7 x nominal supply voltage) and Asymmetry Detection

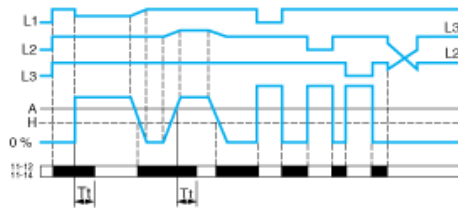

Control of Overvoltage and Undervoltage in Window Mode

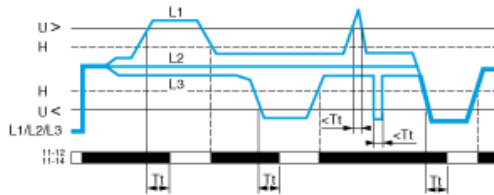

Legend

- A Asymmetry threshold (adjustable from 5...15% of the nominal supply voltage)
- Tt Time delay after crossing of threshold (adjustable on front panel)
- H Hysteresis
- U> Overvoltage threshold
- U< Undervoltage threshold
- L1, L2, L3 Phases of the supply voltage monitored
- 11-12, 11-14 Output relay connections (refer to Connections and Schema)
- Relay status: black color = energized.